

AUTOMATIC ROTARY NUMERATOR

INDUSTRIAL MARKING SOLUTIONS

- Consecutive serial numbers can be marked on metal parts - in a simple operation
- Special design ensures that figures advance one at-a-time accurately and automatically
- Impressions are perfectly aligned, evenly spaced, uniformly deep-part after part!
- Applications: Name-plates for Electric Motors, Pumps, Metres and for engines, Bicycles, Frames, Keys etc.

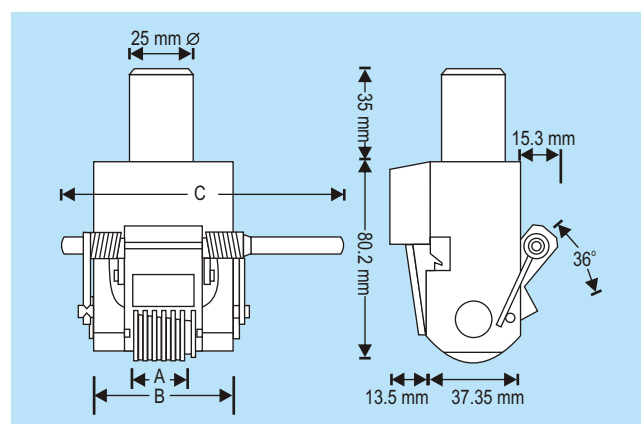

The Standard Automatic Rotary Numerators have Six Number Wheels and Come in the following Sizes

Size	Code	Dimensions (mm)			Character	Actual Size	Length of Impression with 6 wheels (mm)
		A	B	C			
1/16"	6AN 062	14.4	49.3	109.0	2.50	234567	13.5
2.0mm	6 AN 020	16.8	51.6	109.0	2.90	234567	15.7
3.0 mm	6 AN 030	25.3	60.2	123.0	4.32	234567	23.4
4.0 mm	6 AN 040						

Stamping characters on numerator wheels have the same style as Interchangeable Steel Types for providing a uniform appearance when marking metals labels or name plates.

Special numerators with more than six wheels, alpha or letter wheels, prefix or suffix additional types or logo for fixed data, repeat or triplicate action for 2 or 3 part components, etc. Made on special order. Prices for special numerators will be quoted on request.